

General

1

These accessories are a range of devices for completing a pneumatic circuit. These valves, with their special functions, are inserted between two valves, between a valve and a cylinder, or following a cylinder.

One of the particular characteristic of these accessories is that they are automatically actuated without the need for external commands. Usually, operation and idle are controlled by the presence or absence of pressure as, for example, in the case of quick exhaust valves which pilots itself as a selector, changing the flow direction as the signal goes off and on.

On the other hand, other components are inert. That is, they do not have any internal variable function which is sensitive to pressure. Among these components are silencers, manifolds and flow regulators.

There are also the flow regulators, which like electronic components, can be defined as variable resistences. They are fundamental in regulating the flow rate, provide precise timings and regulate the cylinders' speed.

The selector valves, with "AND" and "OR" functions, are logic functions components which often are an essential element. Furthermore, they are built to allow high flow rate which cannot be obtained by classic pneumatic logic.

The block valves lock the cylinder in a position, avoiding unexpected depressurization of the cylinder's chamber due to lack of compressed air at the inlet port. Practically, it is a piloted unidirectional valve that blocks the exhaust port when there is no air in the pilot circuit.

Finally the economizer valves are in fact a pressure reducer valves installed between valve and cylinder for reducing the air consumption. For example this is applicable on the cylinder return stroke without penalizing the exhaust as happens with FRL pressure regulator.

Construction characteristics

We have not listed all different materials used for the construction of these components because the list would be too the long. We use corrosion proof material, brass or anodized aluminium and the most appropriate specific mixture for seals. If more information is required please contact our technical department.



Use and maintenance

In operation pay attention to the minimum and maximum criteria for temperature and pressure, and ensure good quality compressed air. In a dirty environment, protect the exhaust ports. In this case, maintenance is minimal and is necessary only if the air is particularly dirty. The components most subject to damage by the accumulation of dirt are flow regulators with fine regulation and silencers. As for regulators, follow the normal procedure for disassembling, washing with non-chemical cleaning agents and remounting. The silencers need only to be rinsed in petrol or solvent and blown dry with compressed air.

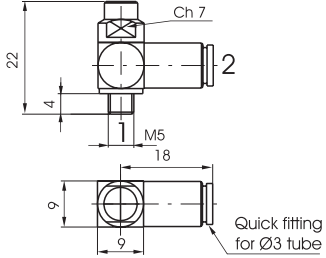

The number of requests for spare seals for flow regulators and shuttle valves are statistically irrelevant. More often, it is necessary to replace the lining of the quick exhaust because of the wear it undergoes due to the particular conditions of operating.

ATTENTION: for lubrication use class H hydraulic oils, for example Castrol MAGNA GC 32.

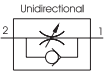
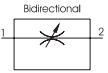
Miniature flow control valve M5 - Ø3 tube

| Ordering code |  | | | |  | | | | | | | | | | | |
|---|--|----------------------|---|------------|---|-------|----------------------|-----------------------|--|--------------|--|--------------|--------|-----------|------------|---------|
| 6.01.305.F | | | | | | | | | | | | | | | | |
| FUNCTION | | | | | | | | | | | | | | | | |
| F 1.2 = Unidirectional 2.1 = Unidirectional 1.1 = Bidirectional | | | | | | | | | | | | | | | | |
| Weight gr. 14 |    | | <table border="1"> <tr> <th>Operational characteristic</th> <th>Fluid</th> <th>Max working pressure</th> <th colspan="2">Operating Temperature</th> <th>Orifice size</th> </tr> <tr> <td></td> <td>Filtered air</td> <td>10 bar</td> <td>Min. -5°C</td> <td>Max. +70°C</td> <td>mm. 1,5</td> </tr> </table> | | Operational characteristic | Fluid | Max working pressure | Operating Temperature | | Orifice size | | Filtered air | 10 bar | Min. -5°C | Max. +70°C | mm. 1,5 |
| Operational characteristic | Fluid | Max working pressure | Operating Temperature | | Orifice size | | | | | | | | | | | |
| | Filtered air | 10 bar | Min. -5°C | Max. +70°C | mm. 1,5 | | | | | | | | | | | |

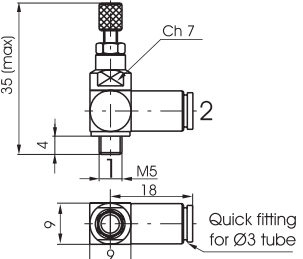

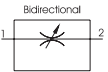
Miniature flow control valve M5 - Ø3 tube, with adjustment knob

| Ordering code |  | | | |  | | | | | | | | | | | |
|---|---|----------------------|---|------------|---|-------|----------------------|-----------------------|--|--------------|--|--------------|--------|-----------|------------|---------|
| 6.01.305.FP | | | | | | | | | | | | | | | | |
| FUNCTION | | | | | | | | | | | | | | | | |
| F 1.2 = Unidirectional 2.1 = Unidirectional 1.1 = Bidirectional | | | | | | | | | | | | | | | | |
| Weight gr. 16 |    | | <table border="1"> <tr> <th>Operational characteristic</th> <th>Fluid</th> <th>Max working pressure</th> <th colspan="2">Operating Temperature</th> <th>Orifice size</th> </tr> <tr> <td></td> <td>Filtered air</td> <td>10 bar</td> <td>Min. -5°C</td> <td>Max. +70°C</td> <td>mm. 1,5</td> </tr> </table> | | Operational characteristic | Fluid | Max working pressure | Operating Temperature | | Orifice size | | Filtered air | 10 bar | Min. -5°C | Max. +70°C | mm. 1,5 |
| Operational characteristic | Fluid | Max working pressure | Operating Temperature | | Orifice size | | | | | | | | | | | |
| | Filtered air | 10 bar | Min. -5°C | Max. +70°C | mm. 1,5 | | | | | | | | | | | |

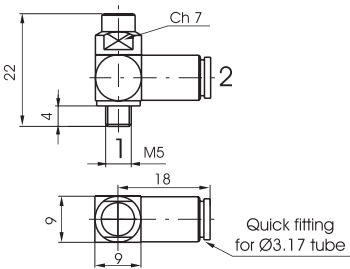
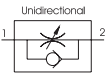
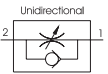
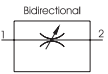
Miniature flow control valve M5 - Ø3,17 tube

| Ordering code |  | | | |  | | | | | | | | | | | |
|---|--|----------------------|---|------------|---|-------|----------------------|-----------------------|--|--------------|--|--------------|--------|-----------|------------|---------|
| 6.01.315.F | | | | | | | | | | | | | | | | |
| FUNCTION | | | | | | | | | | | | | | | | |
| F 1.2 = Unidirectional 2.1 = Unidirectional 1.1 = Bidirectional | | | | | | | | | | | | | | | | |
| Weight gr. 14 |    | | <table border="1"> <tr> <th>Operational characteristic</th> <th>Fluid</th> <th>Max working pressure</th> <th colspan="2">Operating Temperature</th> <th>Orifice size</th> </tr> <tr> <td></td> <td>Filtered air</td> <td>10 bar</td> <td>Min. -5°C</td> <td>Max. +70°C</td> <td>mm. 1,5</td> </tr> </table> | | Operational characteristic | Fluid | Max working pressure | Operating Temperature | | Orifice size | | Filtered air | 10 bar | Min. -5°C | Max. +70°C | mm. 1,5 |
| Operational characteristic | Fluid | Max working pressure | Operating Temperature | | Orifice size | | | | | | | | | | | |
| | Filtered air | 10 bar | Min. -5°C | Max. +70°C | mm. 1,5 | | | | | | | | | | | |

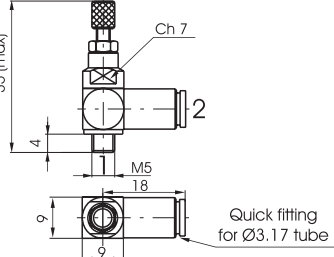
Miniature flow control valve M5 - Ø3,17 tube, with adjustment

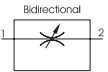
| Ordering code |  | | | |  | | | | | | | | | | | |
|---|--|----------------------|---|------------|---|-------|----------------------|-----------------------|--|--------------|--|--------------|--------|-----------|------------|---------|
| 6.01.315.FP | | | | | | | | | | | | | | | | |
| FUNCTION | | | | | | | | | | | | | | | | |
| F 1.2 = Unidirectional 2.1 = Unidirectional 1.1 = Bidirectional | | | | | | | | | | | | | | | | |
| Weight gr. 16 |    | | <table border="1"> <tr> <th>Operational characteristic</th> <th>Fluid</th> <th>Max working pressure</th> <th colspan="2">Operating Temperature</th> <th>Orifice size</th> </tr> <tr> <td></td> <td>Filtered air</td> <td>10 bar</td> <td>Min. -5°C</td> <td>Max. +70°C</td> <td>mm. 1,5</td> </tr> </table> | | Operational characteristic | Fluid | Max working pressure | Operating Temperature | | Orifice size | | Filtered air | 10 bar | Min. -5°C | Max. +70°C | mm. 1,5 |
| Operational characteristic | Fluid | Max working pressure | Operating Temperature | | Orifice size | | | | | | | | | | | |
| | Filtered air | 10 bar | Min. -5°C | Max. +70°C | mm. 1,5 | | | | | | | | | | | |

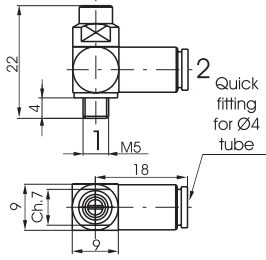
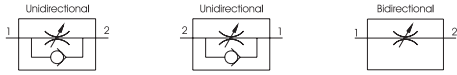

Miniature flow control valve M5 - Ø4 tube

| | | | | | |
|--|--------------|---|---|------------|--------------|
| Ordering code | |  |  | | |
| 6.01.45.F | | | | | |
| FUNCTION | | | | | |
| 1.2 = Unidirectional 2.1 = Unidirectional 1.1 = Bidirectional | | | | | |
| Weight gr. 14 | | | | | |
|  | | | | | |
| Operational characteristic | Fluid | Max working pressure | Operating Temperature | | Orifice size |
| | Filtered air | 10 bar | Min. -5°C | Max. +70°C | |

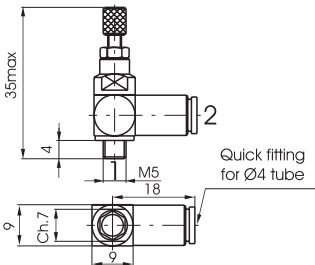
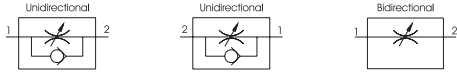

Miniature flow control valve M5 - Ø4 tube, with adjustment knob

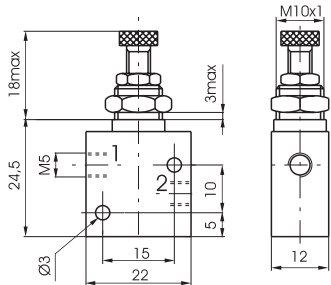
| | | | | | |
|---|--------------|---|---|------------|--------------|
| Ordering code | |  |  | | |
| 6.01.45.FP | | | | | |
| FUNCTION | | | | | |
| 1.2 = Unidirectional 2.1 = Unidirectional 1.1 = Bidirectional | | | | | |
| Weight gr. 16 | | | | | |
|  | | | | | |
| Operational characteristic | Fluid | Max working pressure | Operating Temperature | | Orifice size |
| | Filtered air | 10 bar | Min. -5°C | Max. +70°C | |

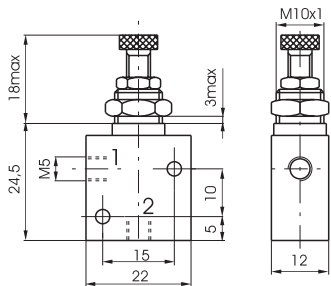

Flow control valve M5 - in line ports

| | | | | | |
|--|--------------|---|---|------------|--------------|
| Ordering code | |  |  | | |
| 6.01.F | | | | | |
| FUNCTION | | | | | |
| 05 = Unidirectional 05/2 = Bidirectional | | | | | |
| Weight gr. 48 | | | | | |
|  | | | | | |
| Operational characteristic | Fluid | Max working pressure | Operating Temperature | | Orifice size |
| | Filtered air | 10 bar | Min. -5°C | Max. +70°C | |

Flow control valve M5 - port at 90°

| | | | | | |
|--|--------------|---|---|------------|--------------|
| Ordering code | |  |  | | |
| 6.01.05.F | | | | | |
| FUNCTION | | | | | |
| 90 = Unidirectional 90/2 = Bidirectional | | | | | |
| Weight gr. 48 | | | | | |
|  | | | | | |
| Operational characteristic | Fluid | Max working pressure | Operating Temperature | | Orifice size |
| | Filtered air | 10 bar | Min. -5°C | Max. +70°C | |

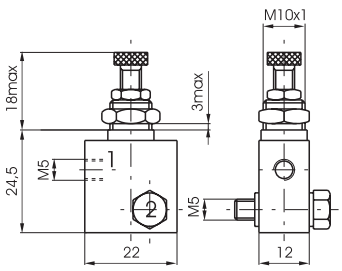

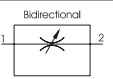
Flow control valve M5 - with a through bolt

| | | | | | | |
|---|---|----------------------|--|------------|---|--|
| Ordering code |  | | | |  | |
| 6.01.05.F | | | | | | |
| FUNCTION F 180 = Unidirectional 180/2 = Bidirectional | | | | | | |
| Weight gr. 52 |  | |  | | | |
| Operational characteristic | Fluid | Max working pressure | Operating Temperature | | Orifice size | |
| | Filtered air | 10 bar | Min. -5°C | Max. +70°C | mm. 2 | |

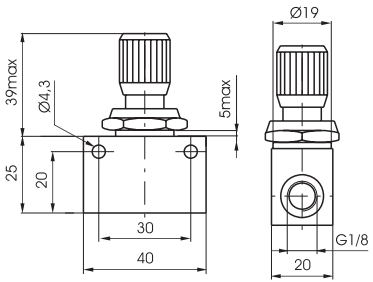
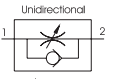
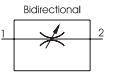
Flow control valve G1/8" - ultrasensitive

| | | | | | | |
|---|---|----------------------|---|------------|---|--|
| Ordering code |  | | | |  | |
| 6.01.18/F | | | | | | |
| FUNCTION F 4 = Unidirectional 5 = Bidirectional | | | | | | |
| Weight gr. 100 |  | |  | | | |
| Operational characteristic | Fluid | Max working pressure | Operating Temperature | | Orifice size | |
| | Filtered air | 10 bar | Min. -5°C | Max. +70°C | mm. 3 | |

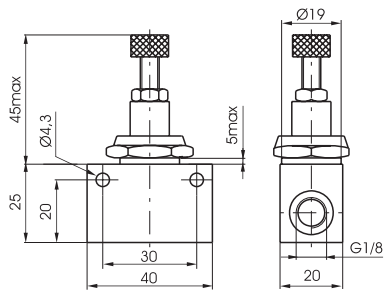
Flow control valve G1/8" - ultrasensitive with lock nut

| | | | | | | |
|---|--|----------------------|--|------------|--|--|
| Ordering code |  | | | |  | |
| 6.01.18/F | | | | | | |
| FUNCTION F 6 = Unidirectional 7 = Bidirectional | | | | | | |
| Weight gr. 105 |  | |  | | | |
| Operational characteristic | Fluid | Max working pressure | Operating Temperature | | Orifice size | |
| | Filtered air | 10 bar | Min. -5°C | Max. +70°C | mm. 3 | |

Flow control valve G1/8"

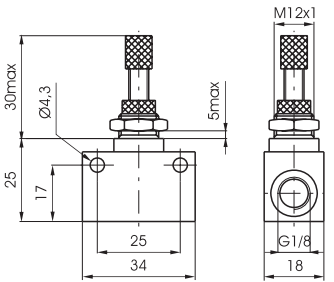
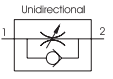
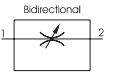
| | | | | | | |
|--|--|----------------------|--|------------|--|--|
| Ordering code |  | | | |  | |
| 6.01.F | | | | | | |
| FUNCTION F 18N = Unidirectional 18NE = Unidir. economic vers. 18/1N = Bidirectional 18/1NE = Bidir. economic vers. | | | | | | |
| Weight gr. 50 |  | |  | | | |
| Operational characteristic | Fluid | Max working pressure | Operating Temperature | | Orifice size | |
| | Filtered air | 10 bar | Min. -5°C | Max. +70°C | mm. 4 | |

1

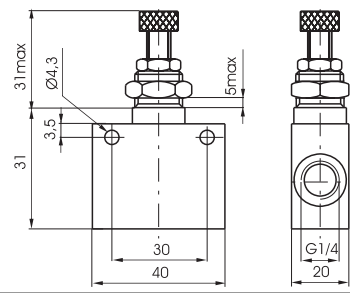
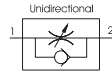

Flow control valve G1/4" - compact typ - unidirectional

| | | | | | | |
|-----------------------------------|---|----------------------|-----------------------|------------|---|--|
| Ordering code |  | | | |  | |
| 6.01.14/1 | | | | | | |
| Weight gr. 100 |  | | | | | |
| Operational characteristic | Fluid | Max working pressure | Operating Temperature | | Orifice size | |
| | Filtered air | 10 bar | Min. -5°C | Max. +70°C | mm. 5,5 | |

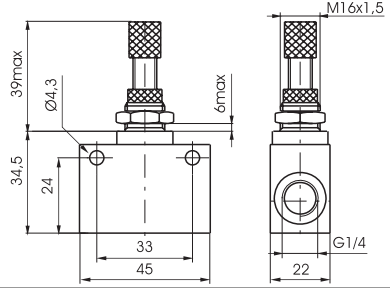
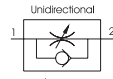
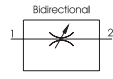
Flow control valve G1/4"

| | | | | | | |
|--|--|----------------------|-----------------------|------------|---|--|
| Ordering code |  | | | |  | |
| 6.01.F | | | | | | |
| F FUNCTION 14N = Unidirectional 14/1N = Bidirectional |   | | | | | |
| Weight gr. 105 | | | | | | |
| Operational characteristic | Fluid | Max working pressure | Operating Temperature | | Orifice size | |
| | Filtered air | 10 bar | Min. -5°C | Max. +70°C | mm. 7 | |

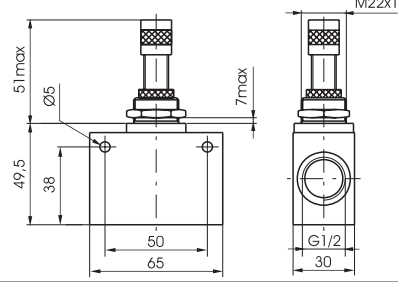
Flow control valve G1/2"

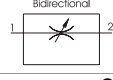
| | | | | | | |
|--|--|----------------------|-----------------------|------------|--|--|
| Ordering code |  | | | |  | |
| 6.01.F | | | | | | |
| F FUNCTION 12N = Unidirectional 12/1N = Bidirectional |   | | | | | |
| Weight gr. 505 | | | | | | |
| Operational characteristic | Fluid | Max working pressure | Operating Temperature | | Orifice size | |
| | Filtered air | 10 bar | Min. -5°C | Max. +70°C | mm. 12 | |

Flow control valve G3/4" - unidirectional

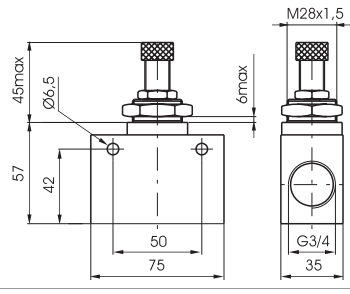
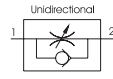
| | | | | | | |
|-----------------------------------|---|----------------------|-----------------------|------------|---|--|
| Ordering code |  | | | |  | |
| 6.01.34 | | | | | | |
| Weight gr. 500 |  | | | | | |
| Operational characteristic | Fluid | Max working pressure | Operating Temperature | | Orifice size | |
| | Filtered air | 10 bar | Min. -5°C | Max. +70°C | mm. 12 | |

Quick exhaust valve - M5 - G1/8" - G1/4" - G1/2"

| |
|---------------|
| Ordering code |
| 6.02.1 |
| CONNECTION |
| 05 = M5 |
| 18 = G 1/8" |
| 14 = G 1/4" |
| 12 = G 1/2" |

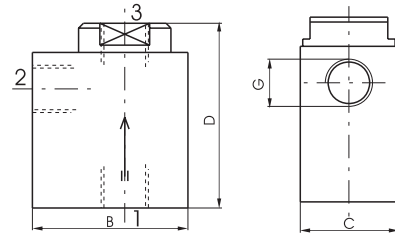

| | G | M5 | 1/8" | 1/4" | 1/2" |
|---|-------------|-----|------|------|------|
| B | 22 | 32 | 35 | 52 | |
| C | 12 | 20 | 25 | 37 | |
| D | 28 | 38 | 50 | 62 | |
| Weight gr. | 50 | 62 | 112 | 310 | |
| Flow rate NI/min at 6 bar with Δ p = 1 | from 1 to 2 | 120 | 480 | 960 | 3300 |
| Flow rate NI/min at 6 bar on free exhaust | from 2 to 3 | 220 | 1100 | 1930 | 6500 |

Weight "see table"

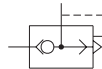

| | | | | |
|----------------------------|--------------|----------------------|-----------------------|------------|
| Operational characteristic | Fluid | Max working pressure | Operating Temperature | |
| | Filtered air | 10 bar | Min. -5°C | Max. +70°C |

Quick exhaust valve in line - M5 - M7 - G1/8"

| |
|-------------------|
| Ordering code |
| 6.02.1.C.L |
| CONNECTION |
| 1 M5 = M5 |
| 04 = tube Ø4 |
| CONNECTION |
| C M5 = M5 |
| M7 = M7 |
| 18 = G1/8" |

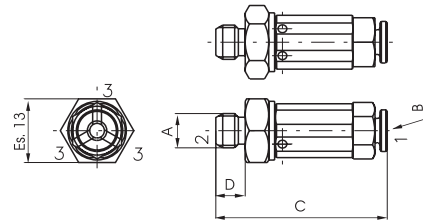

| | A | M5 | M7 | 1/8" | M5 | M7 | 1/8" |
|---|-------------|------|-----|---------|-----|----|------|
| B | | M5 | | tube Ø4 | | | |
| C | 29 | 30,5 | | 34 | 35 | | |
| D | 4,5 | 6 | | 4,5 | 6 | | |
| Weight gr. | | 17 | 18 | | 17 | 18 | |
| Flow rate NI/min at 6 bar with Δ p = 1 | from 1 to 2 | 90 | 110 | 90 | 110 | | |
| Flow rate NI/min at 6 bar on free exhaust | from 2 to 3 | 240 | 350 | 240 | 350 | | |

Weight "see table"

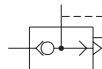

| | | | | |
|----------------------------|--------------|----------------------|-----------------------|------------|
| Operational characteristic | Fluid | Max working pressure | Operating Temperature | |
| | Filtered air | 10 bar | Min. -5°C | Max. +70°C |

Exhaust flow control - M5 - G1/8" - G1/4" - G1/2"

| |
|---------------|
| Ordering code |
| 6.03.1 |
| CONNECTION |
| 05 = M5 |
| 18 = G 1/8" |
| 14 = G 1/4" |
| 12 = G 1/2" |

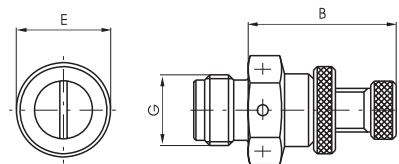

| | G | M5 | 1/8" | 1/4" | 1/2" |
|------------|----|----|------|------|------|
| B | 21 | 18 | 22 | 39 | |
| E | 9 | 13 | 16 | 25 | |
| Weight gr. | 10 | 18 | 32 | 155 | |

Weight "see table"



| | | | | |
|----------------------------|--------------|----------------------|-----------------------|------------|
| Operational characteristic | Fluid | Max working pressure | Operating Temperature | |
| | Filtered air | 10 bar | Min. -5°C | Max. +70°C |

Shuttle valve "OR" - M5 - G1/8" - G1/4"

| | |
|---------------|---------------------------------------|
| Ordering code | 6.04.1 |
| CONNECTION | 05 = M5 18 = G 1/8" 14 = G 1/4" |

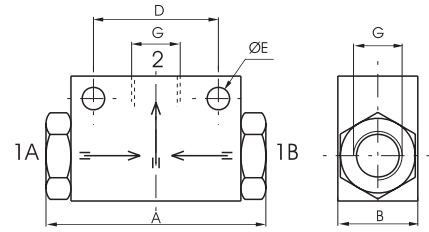

| G | M5 | 1/8" | 1/4" |
|--|---------|------|------|
| A | 27 | 44 | 62 |
| B | 12 | 16 | 22 |
| D | 15 | 25 | 35 |
| E | 3,5 | 4,5 | 5,5 |
| Weight gr. | 33 | 50 | 110 |
| Flow rate at 6 bar with $\Delta p = 1$ | NI/min. | 110 | 700 |

Flow rate at 6 bar with $\Delta p = 1$

Weight "see table"

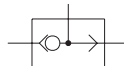

| | | | | |
|----------------------------|--------------|----------------------|-----------------------|------------|
| Operational characteristic | Fluid | Max working pressure | Operating Temperature | |
| | Filtered air | 10 bar | Min. -5°C | Max. +70°C |

Shuttle valve "OR" - T=4

| | |
|---------------|----------------|
| Ordering code | 6.04.04 |
|---------------|----------------|

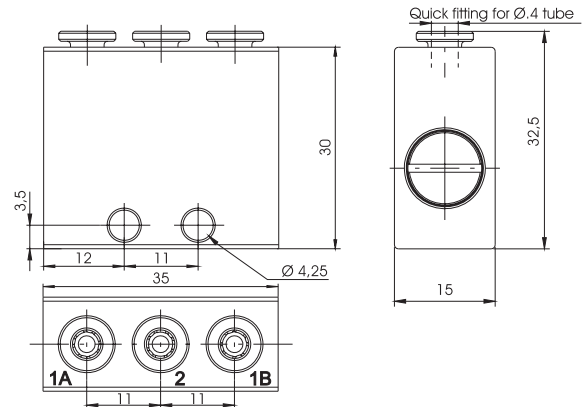

Weight gr. 50

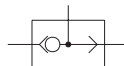

| | | | | | | | |
|----------------------------|-----------------------------|----------------------|-----------------------|------------|---------------------------------|--------------|-------------|
| Operational characteristic | Fluid | Max working pressure | Operating Temperature | | Flow rate 6 bar at $\Delta p=1$ | Orifice size | Connections |
| | Filtered and lubricated air | 10 bar | Min. -5°C | Max. +70°C | 105 NI/min | mm. 2,5 | Fitting T=4 |

Shuttle valve "AND" - M5 - G1/8"

| | |
|---------------|------------------------|
| Ordering code | 6.04.1/1 |
| CONNECTION | 05 = M5 18 = G 1/8" |

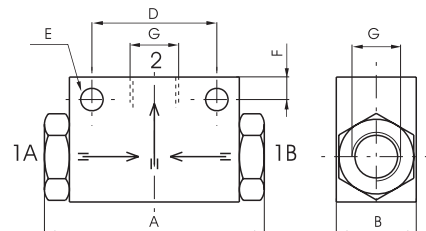

| G | M5 | 1/8" |
|--|---------|------|
| A | 36 | 44 |
| B | 12 | 16 |
| D | 20 | 25 |
| E | 3,2 | 4,5 |
| F | 3,5 | 4,5 |
| Weight gr. | 30 | 50 |
| Flow rate at 6 bar with $\Delta p = 1$ | NI/min. | 100 |

Flow rate at 6 bar with $\Delta p = 1$

Weight "see table"

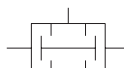

| | | | | |
|----------------------------|--------------|----------------------|-----------------------|------------|
| Operational characteristic | Fluid | Max working pressure | Operating Temperature | |
| | Filtered air | 10 bar | Min. -5°C | Max. +70°C |

Shuttle valve "AND" - T=4

| | | | | | | | |
|-----------------------------------|--------------|----------------------|-----------------------|------------|-------------------------|--------------|-------------|
| Ordering code | | | | | | | |
| 6.04.04/1 | | | | | | | |
| | | | | | | | |
| Weight gr. 50 | | | | | | | |
| Operational characteristic | Fluid | Max working pressure | Operating Temperature | | Flow rate 6 bar at Δp=1 | Orifice size | Connections |
| | Filtered air | 10 bar | Min. -5°C | Max. +70°C | 105 NI/min | mm. 2,5 | Fitting T=4 |

Silencers steel wool - G1/8" - G1/4" - G3/8" - G1/2"

| Ordering code | | | | | | | | | | | | | | | | | | | | | | | | | | |
|-----------------------------------|---|----------------------|-----------------------|------------|--|--|---|------|------|------|------|---|----|----|----|----|---|----|----|----|----|------------|---|----|----|----|
| 6.05.1 | | | | | | | | | | | | | | | | | | | | | | | | | | |
| CONNECTION | | | | | | | | | | | | | | | | | | | | | | | | | | |
| 18 = G 1/8" | | | | | | | | | | | | | | | | | | | | | | | | | | |
| 14 = G 1/4" | | | | | | | | | | | | | | | | | | | | | | | | | | |
| 38 = G 3/8" | | | | | | | | | | | | | | | | | | | | | | | | | | |
| 12 = G 1/2" | | | | | | | | | | | | | | | | | | | | | | | | | | |
| | | | | | | | | | | | | | | | | | | | | | | | | | | |
| | | | | | | | | | | | | | | | | | | | | | | | | | | |
| | <table border="1"> <thead> <tr> <th>G</th> <th>1/8"</th> <th>1/4"</th> <th>3/8"</th> <th>1/2"</th> </tr> </thead> <tbody> <tr> <td>A</td> <td>12</td> <td>13</td> <td>15</td> <td>17</td> </tr> <tr> <td>E</td> <td>14</td> <td>17</td> <td>22</td> <td>27</td> </tr> <tr> <td>Weight gr.</td> <td>8</td> <td>16</td> <td>32</td> <td>44</td> </tr> </tbody> </table> | | | | | | G | 1/8" | 1/4" | 3/8" | 1/2" | A | 12 | 13 | 15 | 17 | E | 14 | 17 | 22 | 27 | Weight gr. | 8 | 16 | 32 | 44 |
| G | 1/8" | 1/4" | 3/8" | 1/2" | | | | | | | | | | | | | | | | | | | | | | |
| A | 12 | 13 | 15 | 17 | | | | | | | | | | | | | | | | | | | | | | |
| E | 14 | 17 | 22 | 27 | | | | | | | | | | | | | | | | | | | | | | |
| Weight gr. | 8 | 16 | 32 | 44 | | | | | | | | | | | | | | | | | | | | | | |
| Weight "see table" | | | | | | | | | | | | | | | | | | | | | | | | | | |
| Operational characteristic | Fluid | Max working pressure | Operating Temperature | | | | | | | | | | | | | | | | | | | | | | | |
| | Filtered air | 10 bar | Min. -5°C | Max. +70°C | | | | | | | | | | | | | | | | | | | | | | |

Silencers brass M5 - G1/8" - G1/4" - G3/8" - G1/2" - G3/4"

| Ordering code | | | | | | | | | | | | | | | | | | | | | | | | | | | | | | | | | | | | | | |
|-----------------------------------|--|----------------------|-----------------------|------------|------|------|-----|----|------|------|------|------|------|----|---|----|----|----|----|----|----|----|---|---|----|----|----|----|----|----|------------|---|---|----|----|----|----|-----|
| 6.06.1 | | | | | | | | | | | | | | | | | | | | | | | | | | | | | | | | | | | | | | |
| CONNECTION | | | | | | | | | | | | | | | | | | | | | | | | | | | | | | | | | | | | | | |
| 05 = M5 | | | | | | | | | | | | | | | | | | | | | | | | | | | | | | | | | | | | | | |
| 18 = G 1/8" | | | | | | | | | | | | | | | | | | | | | | | | | | | | | | | | | | | | | | |
| 14 = G 1/4" | | | | | | | | | | | | | | | | | | | | | | | | | | | | | | | | | | | | | | |
| 38 = G 3/8" | | | | | | | | | | | | | | | | | | | | | | | | | | | | | | | | | | | | | | |
| 12 = G 1/2" | | | | | | | | | | | | | | | | | | | | | | | | | | | | | | | | | | | | | | |
| 34 = G 3/4" | | | | | | | | | | | | | | | | | | | | | | | | | | | | | | | | | | | | | | |
| 01 = G 1" | | | | | | | | | | | | | | | | | | | | | | | | | | | | | | | | | | | | | | |
| | | | | | | | | | | | | | | | | | | | | | | | | | | | | | | | | | | | | | | |
| | | | | | | | | | | | | | | | | | | | | | | | | | | | | | | | | | | | | | | |
| | <table border="1"> <thead> <tr> <th>G</th> <th>M5</th> <th>1/8"</th> <th>1/4"</th> <th>3/8"</th> <th>1/2"</th> <th>3/4"</th> <th>1"</th> </tr> </thead> <tbody> <tr> <td>A</td> <td>17</td> <td>15</td> <td>18</td> <td>28</td> <td>32</td> <td>40</td> <td>50</td> </tr> <tr> <td>D</td> <td>8</td> <td>12</td> <td>15</td> <td>19</td> <td>23</td> <td>29</td> <td>38</td> </tr> <tr> <td>Weight gr.</td> <td>4</td> <td>8</td> <td>15</td> <td>35</td> <td>50</td> <td>92</td> <td>182</td> </tr> </tbody> </table> | | | | | | G | M5 | 1/8" | 1/4" | 3/8" | 1/2" | 3/4" | 1" | A | 17 | 15 | 18 | 28 | 32 | 40 | 50 | D | 8 | 12 | 15 | 19 | 23 | 29 | 38 | Weight gr. | 4 | 8 | 15 | 35 | 50 | 92 | 182 |
| G | M5 | 1/8" | 1/4" | 3/8" | 1/2" | 3/4" | 1" | | | | | | | | | | | | | | | | | | | | | | | | | | | | | | | |
| A | 17 | 15 | 18 | 28 | 32 | 40 | 50 | | | | | | | | | | | | | | | | | | | | | | | | | | | | | | | |
| D | 8 | 12 | 15 | 19 | 23 | 29 | 38 | | | | | | | | | | | | | | | | | | | | | | | | | | | | | | | |
| Weight gr. | 4 | 8 | 15 | 35 | 50 | 92 | 182 | | | | | | | | | | | | | | | | | | | | | | | | | | | | | | | |
| Weight "see table" | | | | | | | | | | | | | | | | | | | | | | | | | | | | | | | | | | | | | | |
| Operational characteristic | Fluid | Max working pressure | Operating Temperature | | | | | | | | | | | | | | | | | | | | | | | | | | | | | | | | | | | |
| | Filtered air | 10 bar | Min. -5°C | Max. +70°C | | | | | | | | | | | | | | | | | | | | | | | | | | | | | | | | | | |

G 1/8" compact check valves

| | |
|------------------------|---|
| Ordering code |  |
| 6.07.18.ⓐ | |
| POPPET | |
| R = NBR VR = VITON® | |

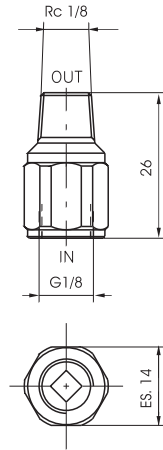

Weight gr. 50

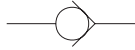

| Operational characteristic | Fluid | Max working pressure | | Operating Temperature | | Flow rate 6 bar at Δp=1 |
|----------------------------|--------------|----------------------|------|-----------------------|------------|-------------------------|
| | Filtered air | Min. 2.5 bar | Max. | Min. -5°C | Max. +70°C | 100 NI/min |

Check valves M5 - G/18" - G1/4" - G3/8" - G1/2"

| | |
|-----------------------|--|
| Ordering code |  |
| 6.07.Ⓣ | |
| POPPET | |
| 05 = NBR - M5 | |
| 18 = NBR - G 1/8" | |
| 14 = NBR - G 1/4" | |
| 38 = NBR - G 3/8" | |
| 12 = NBR - G 1/2" | |
| 18V = VITON® - G 1/8" | |
| 14V = VITON® - G 1/4" | |
| 38V = VITON® - G 3/8" | |
| 12V = VITON® - G 1/2" | |

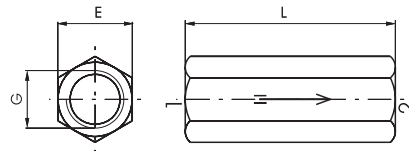

| G | M5 | 1/8" | 1/4" | 3/8" | 1/2" |
|------------|----|------|------|------|------|
| E | 10 | 14 | 17 | 21 | 25 |
| L | 21 | 37 | 48 | 50 | 60 |
| Weight gr. | 14 | 35 | 60 | 85 | 136 |

Flow rate at 6 bar with Δp = 1 NI/min. 160 650 1150 2600 3500

Weight "see table"



| Operational characteristic | Fluid | Max working pressure | Operating Temperature | |
|----------------------------|-----------------------------|----------------------|-----------------------|---------------------|
| | Filtered and lubricated air | 10 bar | Min. -5°C | Max. +70°C (+150°C) |

Manifold 4 ports M5 - G1/8" - G1/4" - G3/8" - G1/2"

| | |
|--|---|
| Ordering code |  |
| 6.08.ⓐ/4 | |
| CONNECTION | |
| 05 = M5 | |
| 18 = G 1/8" 14 = G 1/4" 38 = G 3/8" 12 = G 1/2" | |

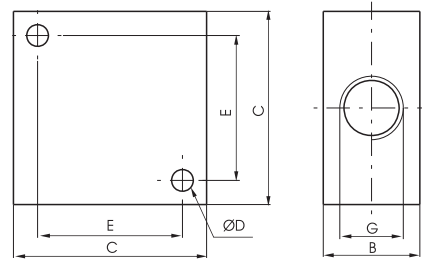

| G | M5 | 1/8" | 1/4" | 3/8" | 1/2" |
|------------|-----|------|------|------|------|
| B | 10 | 16 | 20 | 20 | 30 |
| C | 20 | 32 | 40 | 40 | 50 |
| D | 3,3 | 4,5 | 4,5 | 5,5 | 6,5 |
| E | 14 | 22 | 30 | 30 | 38 |
| Weight gr. | 28 | 38 | 68 | 54 | 135 |

Weight "see table"

| Operational characteristic | Fluid | Max working pressure | Operating Temperature | |
|----------------------------|--------------|----------------------|-----------------------|------------|
| | Filtered air | 20 bar | Min. -5°C | Max. +70°C |

Manifold 10 ports M5 - G1/8" - G1/4" - G3/8" - G1/2"

| | |
|-----------------|--|
| Ordering code | |
| 6.08.0/8 | |
| CONNECTION | |
| 05 = M5 | |
| 18 = G 1/8" | |
| 14 = G 1/4" | |
| 38 = G 3/8" | |
| 12 = G 1/2" | |

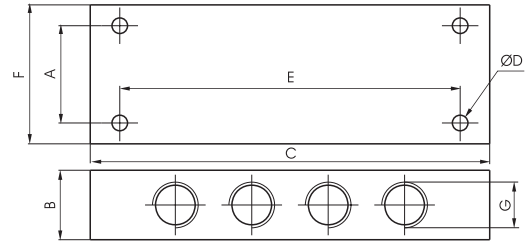

| G | M5 | 1/8" | 1/4" | 3/8" | 1/2" |
|------------|-----|------|------|------|------|
| A | 16 | 20 | 28 | 28 | 36 |
| B | 12 | 18 | 20 | 20 | 30 |
| C | 60 | 90 | 115 | 130 | 170 |
| D | 3,3 | 4,5 | 4,5 | 5,5 | 5,5 |
| E | 50 | 75 | 98 | 112 | 150 |
| F | 22 | 32 | 40 | 40 | 50 |
| Weight gr. | 92 | 110 | 185 | 165 | 460 |

Weight "see table"

| | | | | |
|-----------------------------------|--------------|----------------------|-----------------------|------------|
| Operational characteristic | Fluid | Max working pressure | Operating Temperature | |
| | Filtered air | 20 bar | Min. -5°C | Max. +70°C |

Block valve G1/4"

| | |
|---------------------|--|
| Ordering code | |
| 6.09.14.F | |
| FUNCTION | |
| UN = Unidirectional | |
| BN = Bidirectional | |

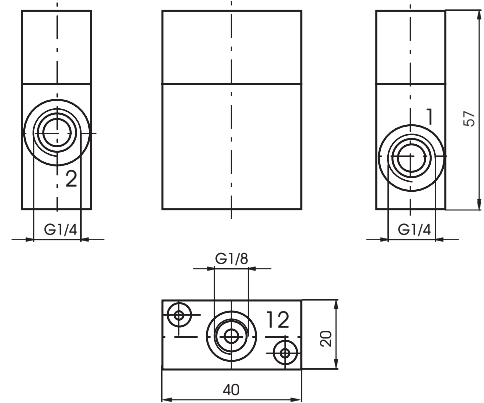

Weight gr. 122

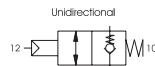

| | | | | | | | |
|-----------------------------------|-----------------------------|----------------------|------------------------|-----------------------|------------|--------------------------------------|--------------|
| Operational characteristic | Fluid | Max working pressure | Min. piloting pressure | Operating Temperature | | Flow rate at 6 bar with $\Delta p=1$ | Orifice size |
| | Filtered and lubricated air | 10 bar | 4 bar | Min. -5°C | Max. +70°C | 700 NI/min | mm. 7 |

Block valve G1/2"

| | |
|---------------------|--|
| Ordering code | |
| 6.09.12.F | |
| FUNCTION | |
| UN = Unidirectional | |
| BN = Bidirectional | |

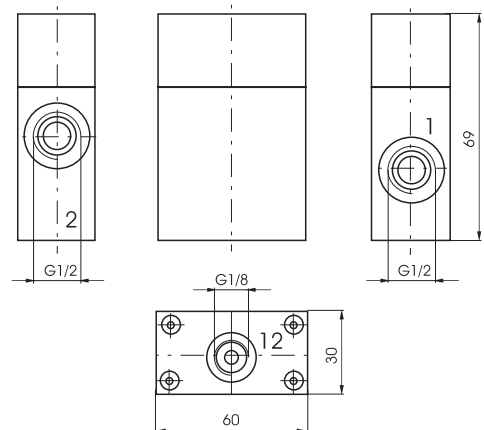

Weight gr. 305

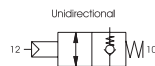

| | | | | | | | |
|-----------------------------------|-----------------------------|----------------------|------------------------|-----------------------|------------|--------------------------------------|--------------|
| Operational characteristic | Fluid | Max working pressure | Min. piloting pressure | Operating Temperature | | Flow rate at 6 bar with $\Delta p=1$ | Orifice size |
| | Filtered and lubricated air | 10 bar | 4 bar | Min. -5°C | Max. +70°C | 2000 NI/min | mm. 12 |

Economizer G1/8" - G1/4"

| | |
|---------------|--|
| Ordering code | |
| 6.11.Ⓢ | |
| CONNECTION | |
| Ⓢ 18 = G 1/8" | |
| 14 = G 1/4" | |

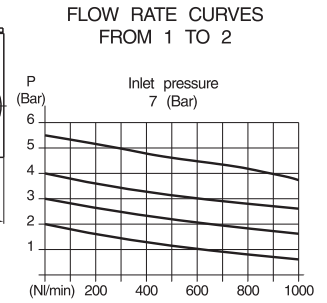
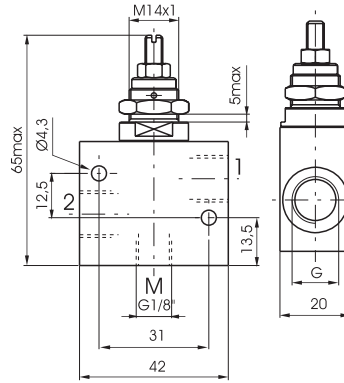

Weight gr. 85



| Operational characteristic | Fluid | Max working pressure | Pressure range | Operating Temperature | | Flow rate from port 2 to 1 | Orifice size |
|----------------------------|-----------------------------|----------------------|----------------|-----------------------|------------|----------------------------|--------------|
| | Filtered and lubricated air | 10 bar | 0 - 5,5 bar | Min. -5°C | Max. +70°C | 860 NI/min | mm. 6 |

Gang mounting manifold for valves and solenoid valves

| | |
|----------------------|--|
| Ordering code | |
| 6.10.18.18/N | |
| No OF POSITIONS | |
| 2 = N. 2 positions | |
| 3 = N. 3 positions | |
| 4 = N. 4 positions | |
| Ⓢ 5 = N. 5 positions | |
| 6 = N. 6 positions | |
| 7 = N. 7 positions | |
| 8 = N. 8 positions | |
| 9 = N. 9 positions | |
| 10 = N. 10 positions | |

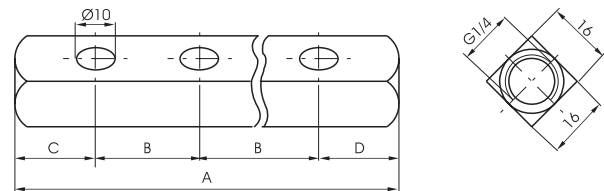

| | * No. OF POSITIONS | | | | | | | | | |
|------------|--------------------|----|-----|-----|-----|-----|-----|-----|-----|--|
| | 2 | 3 | 4 | 5 | 6 | 7 | 8 | 9 | 10 | |
| A | 58 | 76 | 94 | 112 | 130 | 148 | 166 | 184 | 202 | |
| B | 18 | 18 | 18 | 18 | 18 | 18 | 18 | 18 | 18 | |
| C | 20 | 20 | 20 | 20 | 20 | 20 | 20 | 20 | 20 | |
| D | 20 | 20 | 20 | 20 | 20 | 20 | 20 | 20 | 20 | |
| Weight gr. | 55 | 80 | 105 | 130 | 155 | 180 | 205 | 230 | 255 | |

Weight "see table"

Gang mounting manifold for valves and solenoid valves

| | |
|----------------------|--|
| Ordering code | |
| 6.10.18.25/N | |
| No OF POSITIONS | |
| 2 = N. 2 positions | |
| 3 = N. 3 positions | |
| 4 = N. 4 positions | |
| Ⓢ 5 = N. 5 positions | |
| 6 = N. 6 positions | |
| 7 = N. 7 positions | |
| 8 = N. 8 positions | |
| 9 = N. 9 positions | |
| 10 = N. 10 positions | |

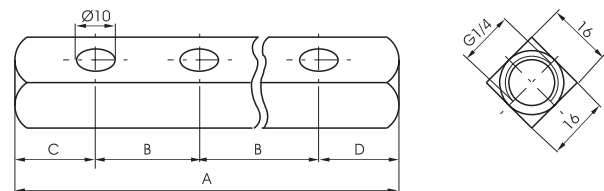

| | * No. OF POSITIONS | | | | | | | | | |
|------------|--------------------|-----|-----|-----|-----|-----|-----|-----|-----|--|
| | 2 | 3 | 4 | 5 | 6 | 7 | 8 | 9 | 10 | |
| A | 70 | 95 | 120 | 145 | 170 | 195 | 220 | 245 | 270 | |
| B | 25 | 25 | 25 | 25 | 25 | 25 | 25 | 25 | 25 | |
| C | 20 | 20 | 20 | 20 | 20 | 20 | 20 | 20 | 20 | |
| D | 25 | 25 | 25 | 25 | 25 | 25 | 25 | 25 | 25 | |
| Weight gr. | 80 | 115 | 150 | 185 | 220 | 255 | 290 | 325 | 360 | |

Weight "see table"

Gang mounting manifold for valves and solenoid valves

| |
|----------------------|
| Ordering code |
| 6.10.18.26/N |
| No OF POSITIONS |
| 2 = N. 2 positions |
| 3 = N. 3 positions |
| 4 = N. 4 positions |
| 5 = N. 5 positions |
| 6 = N. 6 positions |
| 7 = N. 7 positions |
| 8 = N. 8 positions |
| 9 = N. 9 positions |
| 10 = N. 10 positions |

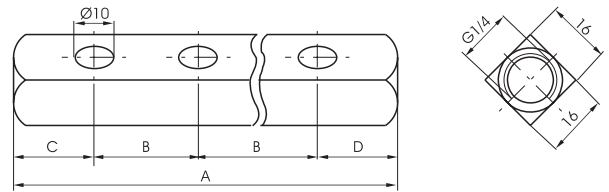

| | * No. OF POSITIONS | | | | | | | | | |
|------------|--------------------|-----|-----|-----|-----|-----|-----|-----|-----|--|
| | 2 | 3 | 4 | 5 | 6 | 7 | 8 | 9 | 10 | |
| A | 66 | 92 | 118 | 144 | 170 | 196 | 222 | 248 | 274 | |
| B | 26 | 26 | 26 | 26 | 26 | 26 | 26 | 26 | 26 | |
| C | 20 | 20 | 20 | 20 | 20 | 20 | 20 | 20 | 20 | |
| D | 20 | 20 | 20 | 20 | 20 | 20 | 20 | 20 | 20 | |
| Weight gr. | 70 | 110 | 145 | 185 | 220 | 260 | 300 | 340 | 375 | |

Weight "see table"

Gang mounting manifold for valves and solenoid valves

| |
|----------------------|
| Ordering code |
| 6.10.18.30/N |
| No OF POSITIONS |
| 2 = N. 2 positions |
| 3 = N. 3 positions |
| 4 = N. 4 positions |
| 5 = N. 5 positions |
| 6 = N. 6 positions |
| 7 = N. 7 positions |
| 8 = N. 8 positions |
| 9 = N. 9 positions |
| 10 = N. 10 positions |

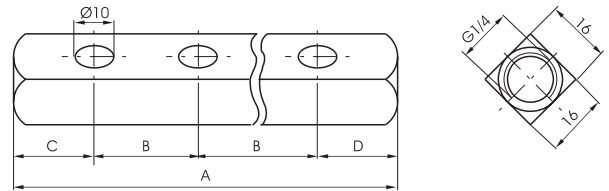

| | * No. OF POSITIONS | | | | | | | | | |
|------------|--------------------|-----|-----|-----|-----|-----|-----|-----|-----|--|
| | 2 | 3 | 4 | 5 | 6 | 7 | 8 | 9 | 10 | |
| A | 80 | 110 | 140 | 170 | 200 | 230 | 260 | 290 | 320 | |
| B | 30 | 30 | 30 | 30 | 30 | 30 | 30 | 30 | 30 | |
| C | 25 | 25 | 25 | 25 | 25 | 25 | 25 | 25 | 25 | |
| D | 25 | 25 | 25 | 25 | 25 | 25 | 25 | 25 | 25 | |
| Weight gr. | 100 | 140 | 180 | 220 | 260 | 300 | 340 | 380 | 420 | |

Weight "see table"

Gang mounting manifold for valves and solenoid valves

| |
|----------------------|
| Ordering code |
| 6.10.18.32/N |
| No OF POSITIONS |
| 2 = N. 2 positions |
| 3 = N. 3 positions |
| 4 = N. 4 positions |
| 5 = N. 5 positions |
| 6 = N. 6 positions |
| 7 = N. 7 positions |
| 8 = N. 8 positions |
| 9 = N. 9 positions |
| 10 = N. 10 positions |

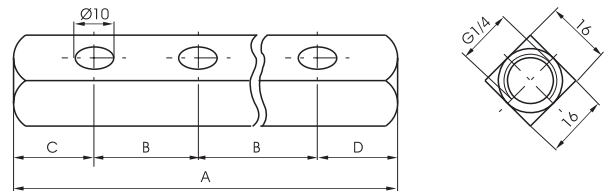

| | * No. OF POSITIONS | | | | | | | | | |
|------------|--------------------|-----|-----|-----|-----|-----|-----|-----|-----|--|
| | 2 | 3 | 4 | 5 | 6 | 7 | 8 | 9 | 10 | |
| A | 82 | 114 | 146 | 178 | 210 | 242 | 274 | 306 | 338 | |
| B | 32 | 32 | 32 | 32 | 32 | 32 | 32 | 32 | 32 | |
| C | 25 | 25 | 25 | 25 | 25 | 25 | 25 | 25 | 25 | |
| D | 25 | 25 | 25 | 25 | 25 | 25 | 25 | 25 | 25 | |
| Weight gr. | 100 | 145 | 190 | 235 | 280 | 325 | 370 | 415 | 460 | |

Weight "see table"

Gang mounting manifold for valves and solenoid valves

| |
|----------------------|
| Ordering code |
| 6.10.18.35/N |
| No OF POSITIONS |
| 2 = N. 2 positions |
| 3 = N. 3 positions |
| 4 = N. 4 positions |
| 5 = N. 5 positions |
| 6 = N. 6 positions |
| 7 = N. 7 positions |
| 8 = N. 8 positions |
| 9 = N. 9 positions |
| 10 = N. 10 positions |

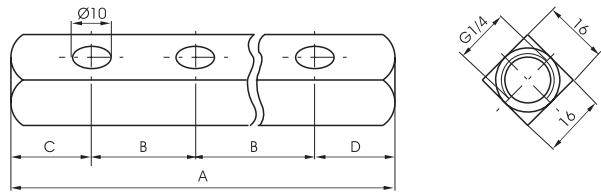

| | * No. OF POSITIONS | | | | | | | | | |
|------------|--------------------|-----|-----|-----|-----|-----|-----|-----|-----|--|
| | 2 | 3 | 4 | 5 | 6 | 7 | 8 | 9 | 10 | |
| A | 89 | 124 | 159 | 194 | 229 | 264 | 299 | 334 | 369 | |
| B | 35 | 35 | 35 | 35 | 35 | 35 | 35 | 35 | 35 | |
| C | 27 | 27 | 27 | 27 | 27 | 27 | 27 | 27 | 27 | |
| D | 27 | 27 | 27 | 27 | 27 | 27 | 27 | 27 | 27 | |
| Weight gr. | 110 | 160 | 210 | 260 | 310 | 360 | 410 | 460 | 510 | |

Weight "see table"

Gang mounting manifold for valves and solenoid valves

| |
|----------------------|
| Ordering code |
| 6.10.14.20/N |
| No OF POSITIONS |
| 2 = N. 2 positions |
| 3 = N. 3 positions |
| 4 = N. 4 positions |
| 5 = N. 5 positions |
| 6 = N. 6 positions |
| 7 = N. 7 positions |
| 8 = N. 8 positions |
| 9 = N. 9 positions |
| 10 = N. 10 positions |

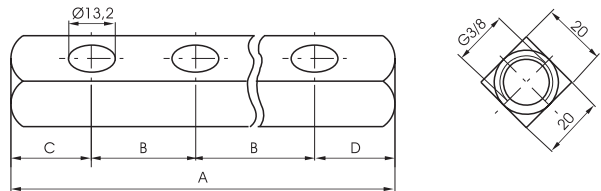

| | * No. OF POSITIONS | | | | | | | | | |
|------------|--------------------|------|------|------|------|------|------|------|------|--|
| | 2 | 3 | 4 | 5 | 6 | 7 | 8 | 9 | 10 | |
| A | 65 | 85 | 105 | 125 | 145 | 165 | 185 | 205 | 225 | |
| B | 20 | 20 | 20 | 20 | 20 | 20 | 20 | 20 | 20 | |
| C | 22,5 | 22,5 | 22,5 | 22,5 | 22,5 | 22,5 | 22,5 | 22,5 | 22,5 | |
| D | 22,5 | 22,5 | 22,5 | 22,5 | 22,5 | 22,5 | 22,5 | 22,5 | 22,5 | |
| Weight gr. | 130 | 150 | 190 | 190 | 210 | 230 | 250 | 270 | 290 | |

Weight "see table"

Gang mounting manifold for valves and solenoid valves

| |
|----------------------|
| Ordering code |
| 6.10.14.25/N |
| No OF POSITIONS |
| 2 = N. 2 positions |
| 3 = N. 3 positions |
| 4 = N. 4 positions |
| 5 = N. 5 positions |
| 6 = N. 6 positions |
| 7 = N. 7 positions |
| 8 = N. 8 positions |
| 9 = N. 9 positions |
| 10 = N. 10 positions |

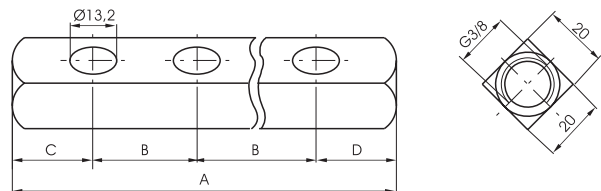

| | * No. OF POSITIONS | | | | | | | | | |
|------------|--------------------|-----|-----|-----|-----|-----|-----|-----|-----|--|
| | 2 | 3 | 4 | 5 | 6 | 7 | 8 | 9 | 10 | |
| A | 75 | 100 | 125 | 150 | 175 | 200 | 225 | 250 | 275 | |
| B | 25 | 25 | 25 | 25 | 25 | 25 | 25 | 25 | 25 | |
| C | 25 | 25 | 25 | 25 | 25 | 25 | 25 | 25 | 25 | |
| D | 25 | 25 | 25 | 25 | 25 | 25 | 25 | 25 | 25 | |
| Weight gr. | 140 | 170 | 200 | 230 | 260 | 290 | 320 | 350 | 380 | |

Weight "see table"

Gang mounting manifold for valves and solenoid valves

| |
|----------------------|
| Ordering code |
| 6.10.14.30/N |
| No OF POSITIONS |
| 2 = N. 2 positions |
| 3 = N. 3 positions |
| 4 = N. 4 positions |
| 5 = N. 5 positions |
| 6 = N. 6 positions |
| 7 = N. 7 positions |
| 8 = N. 8 positions |
| 9 = N. 9 positions |
| 10 = N. 10 positions |

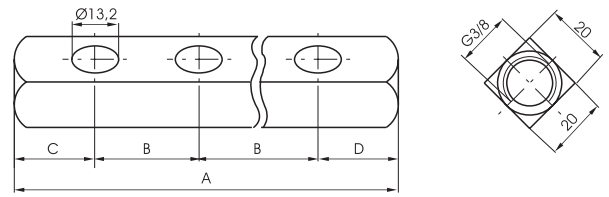

| | * No. OF POSITIONS | | | | | | | | | |
|------------|--------------------|-----|-----|-----|-----|-----|-----|-----|-----|--|
| | 2 | 3 | 4 | 5 | 6 | 7 | 8 | 9 | 10 | |
| A | 80 | 110 | 140 | 170 | 200 | 230 | 260 | 290 | 320 | |
| B | 30 | 30 | 30 | 30 | 30 | 30 | 30 | 30 | 30 | |
| C | 25 | 25 | 25 | 25 | 25 | 25 | 25 | 25 | 25 | |
| D | 25 | 25 | 25 | 25 | 25 | 25 | 25 | 25 | 25 | |
| Weight gr. | 150 | 190 | 230 | 270 | 310 | 350 | 390 | 430 | 470 | |

Weight "see table"

Gang mounting manifold for valves and solenoid valves

| |
|----------------------|
| Ordering code |
| 6.10.14.35/N |
| No OF POSITIONS |
| 2 = N. 2 positions |
| 3 = N. 3 positions |
| 4 = N. 4 positions |
| 5 = N. 5 positions |
| 6 = N. 6 positions |
| 7 = N. 7 positions |
| 8 = N. 8 positions |
| 9 = N. 9 positions |
| 10 = N. 10 positions |

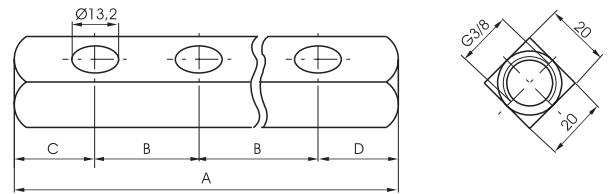

| | * No. OF POSITIONS | | | | | | | | | |
|------------|--------------------|-----|-----|-----|-----|-----|-----|-----|-----|--|
| | 2 | 3 | 4 | 5 | 6 | 7 | 8 | 9 | 10 | |
| A | 85 | 120 | 155 | 190 | 225 | 260 | 295 | 335 | 365 | |
| B | 35 | 35 | 35 | 35 | 35 | 35 | 35 | 35 | 35 | |
| C | 30 | 30 | 30 | 30 | 30 | 30 | 30 | 30 | 30 | |
| D | 20 | 20 | 20 | 20 | 20 | 20 | 20 | 20 | 20 | |
| Weight gr. | 160 | 210 | 260 | 310 | 360 | 410 | 460 | 510 | 560 | |

Weight "see table"

Gang mounting manifold for valves and solenoid valves

| |
|----------------------|
| Ordering code |
| 6.10.14.45/N |
| No OF POSITIONS |
| 2 = N. 2 positions |
| 3 = N. 3 positions |
| 4 = N. 4 positions |
| 5 = N. 5 positions |
| 6 = N. 6 positions |
| 7 = N. 7 positions |
| 8 = N. 8 positions |
| 9 = N. 9 positions |
| 10 = N. 10 positions |

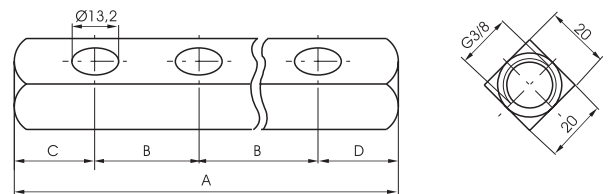

| | * No. OF POSITIONS | | | | | | | | | |
|------------|--------------------|-----|-----|-----|-----|-----|-----|-----|-----|--|
| | 2 | 3 | 4 | 5 | 6 | 7 | 8 | 9 | 10 | |
| A | 115 | 160 | 205 | 250 | 295 | 340 | 385 | 430 | 475 | |
| B | 45 | 45 | 45 | 45 | 45 | 45 | 45 | 45 | 45 | |
| C | 35 | 35 | 35 | 35 | 35 | 35 | 35 | 35 | 35 | |
| D | 35 | 35 | 35 | 35 | 35 | 35 | 35 | 35 | 35 | |
| Weight gr. | 200 | 275 | 350 | 425 | 500 | 575 | 650 | 725 | 800 | |

Weight "see table"